

**DETALHE DE FIXAÇÃO DO TENSOR DO MÓDULO - 01**  
Escala: 1/1

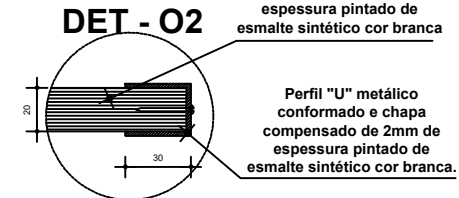

**DETALHE PAINEL DO MÓDULO - 01**  
Escala: 1/1

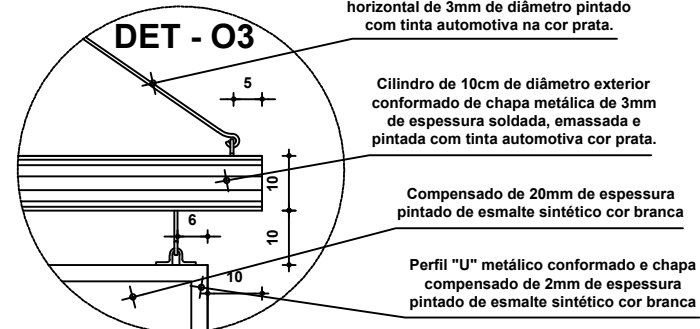

**DETALHE DE FIXAÇÃO DO PAINEL DO MÓDULO - 01**  
Escala: 1/10

