

P1

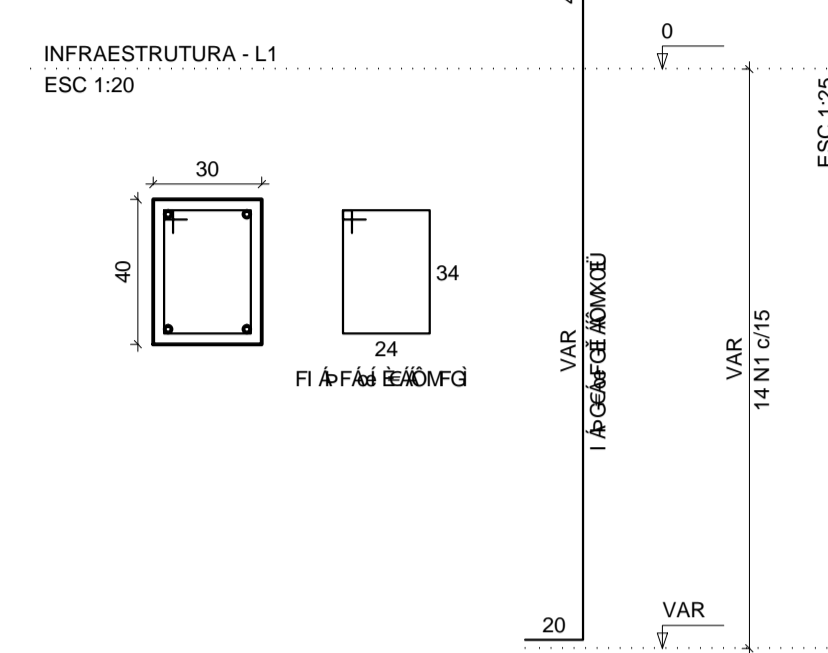

P3=P7

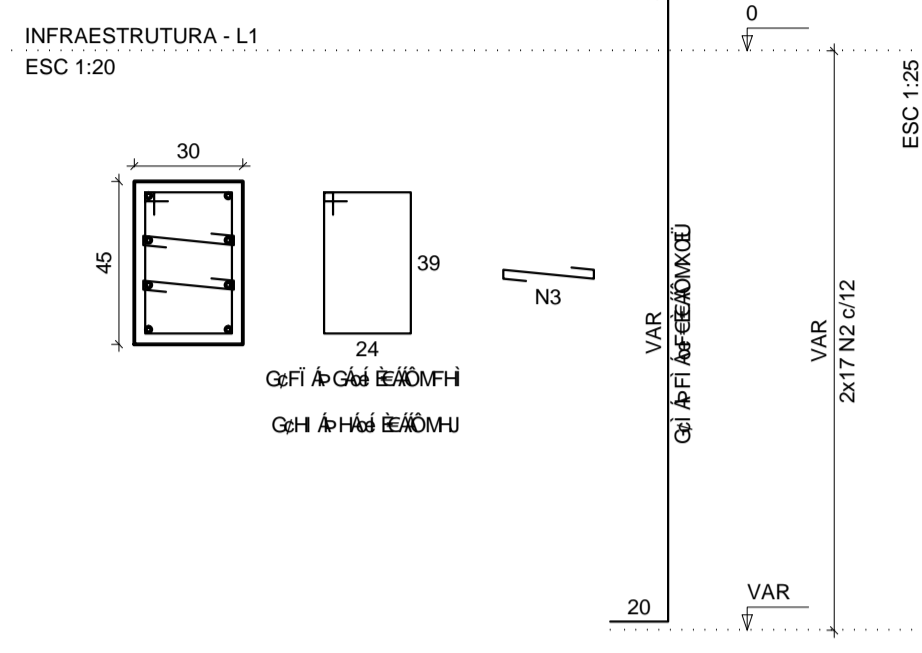

P4

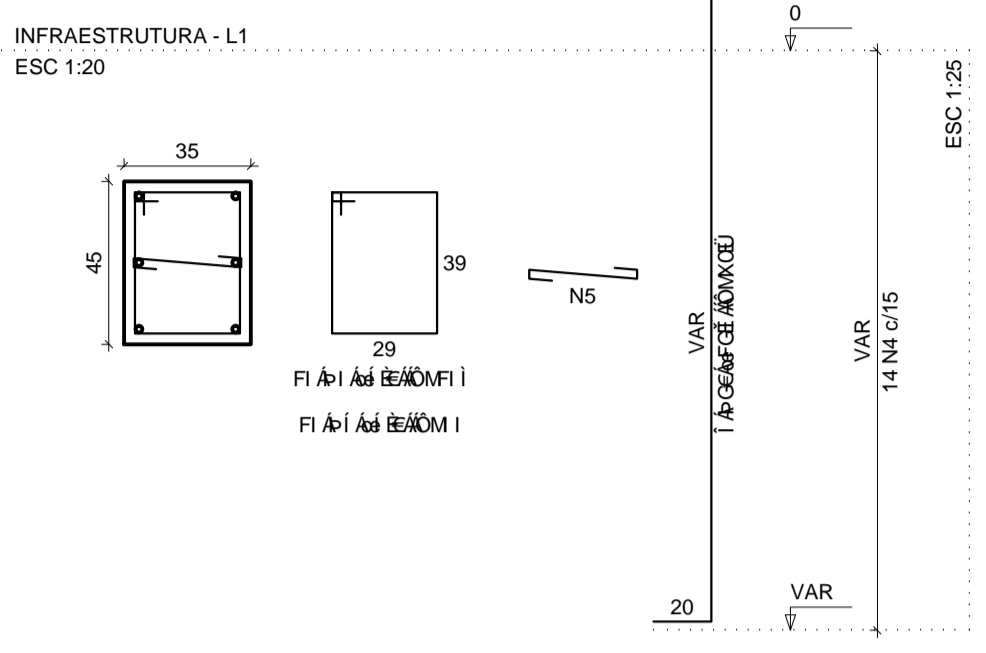

S1=S3=S4=S7

PLANTA
ESC 1:25

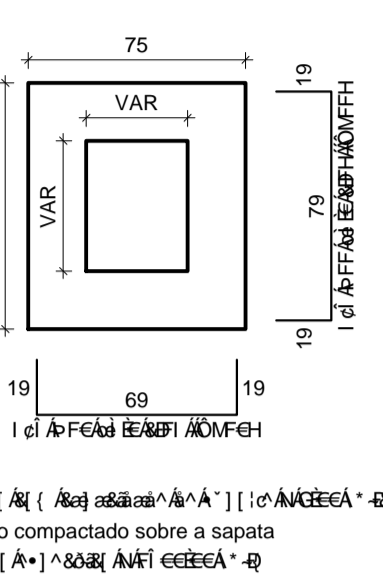

CORTE
ESC 1:25

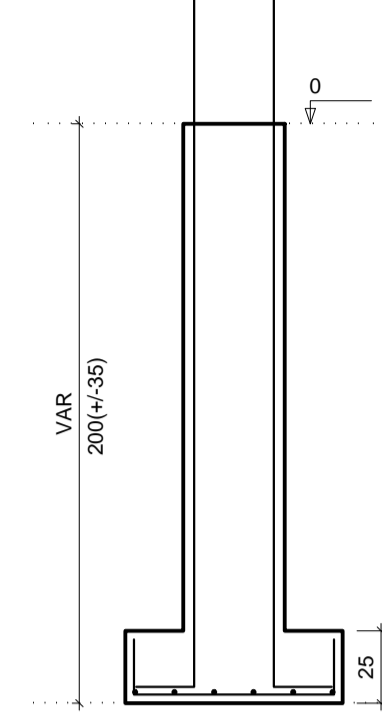

Qtd (kg) / Escala

CE U	N	DIAM	Q	UNIT (cm)	C.TOTAL (cm)
CA60	1	5.0	28	128	3584
	2	5.0	34	138	4692
	3	5.0	68	39	2652
	4	5.0	14	148	2072
	5	5.0	14	44	616
	6	5.0	17	68	1156
	7	5.0	51	78	3978
	8	5.0	14	108	1512
	9	5.0	17	78	1326
	10	8.0	24	103	2472
	11	8.0	24	113	2712
	12	8.0	24	83	1992
	13	8.0	36	98	3528
	14	8.0	6	108	648
	15	8.0	6	118	708
	16	8.0	7	78	546
	17	8.0	6	83	498
	18	10.0	32	VAR	VAR
	19	10.0	4	VAR	VAR
	20	12.5	18	VAR	VAR

Qtd (kg) / Escala

CE U	DIAM	C.TOTAL (m)	PESO + 10 % (kg)
CA50	8.0	131.1	56.9
	10.0	93.6	63.4
	12.5	47.6	50.4
CA60	5.0	215.9	36.6
PESO TOTAL			
CA50		170.7	
CA60		36.6	

X (kg) / Escala / Solo compactado sobre a sapata
7 (kg) / Escala / Solo compactado sobre a sapata

P2

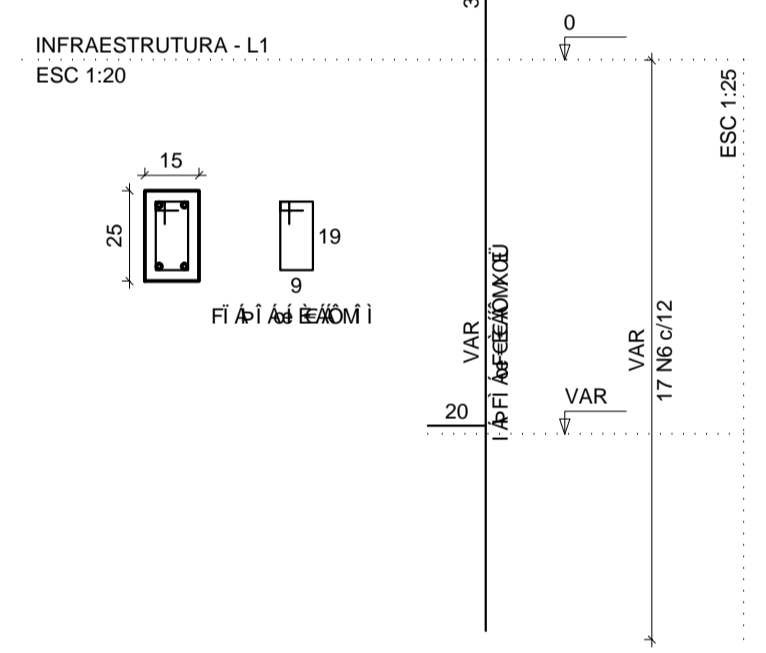

P6=P10=P11

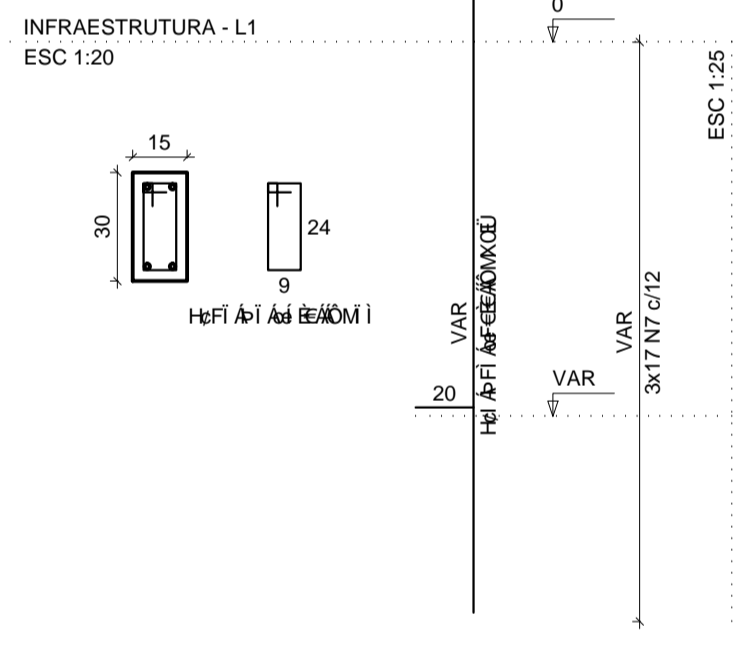

S2=S6=S10=S11

PLANTA
ESC 1:25

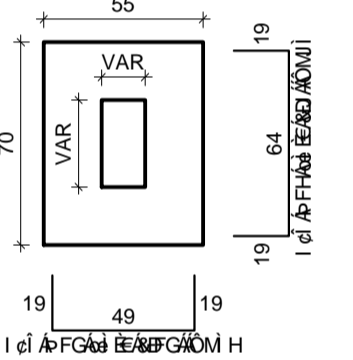

Ú (kg) / Escala / Solo compactado sobre a sapata
] (kg) / Escala / Solo compactado sobre a sapata

CORTE
ESC 1:25

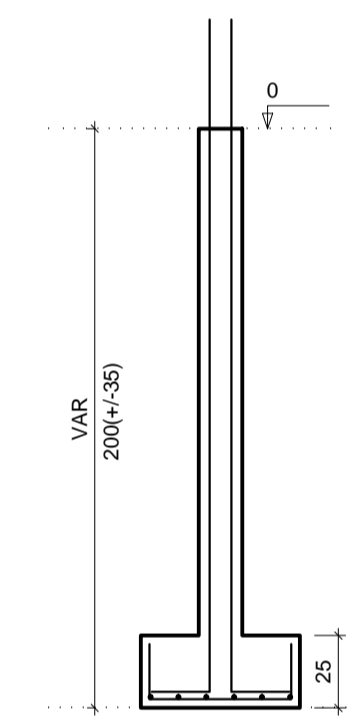

P5

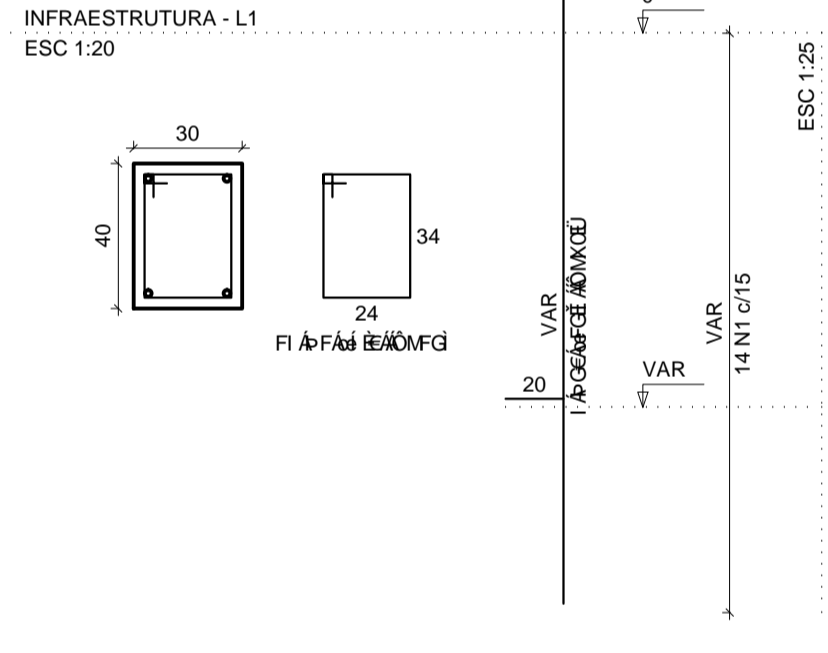

S5

PLANTA
ESC 1:25

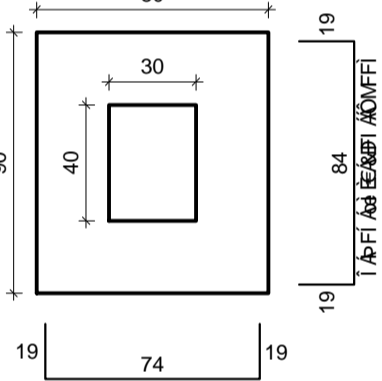

Ú (kg) / Escala / Solo compactado sobre a sapata
] (kg) / Escala / Solo compactado sobre a sapata

CORTE
ESC 1:25

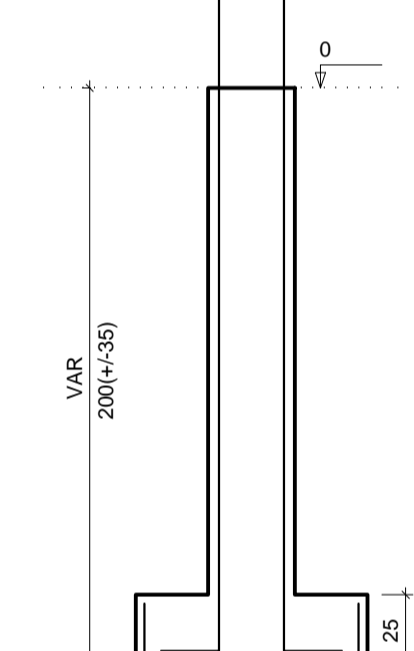

P8

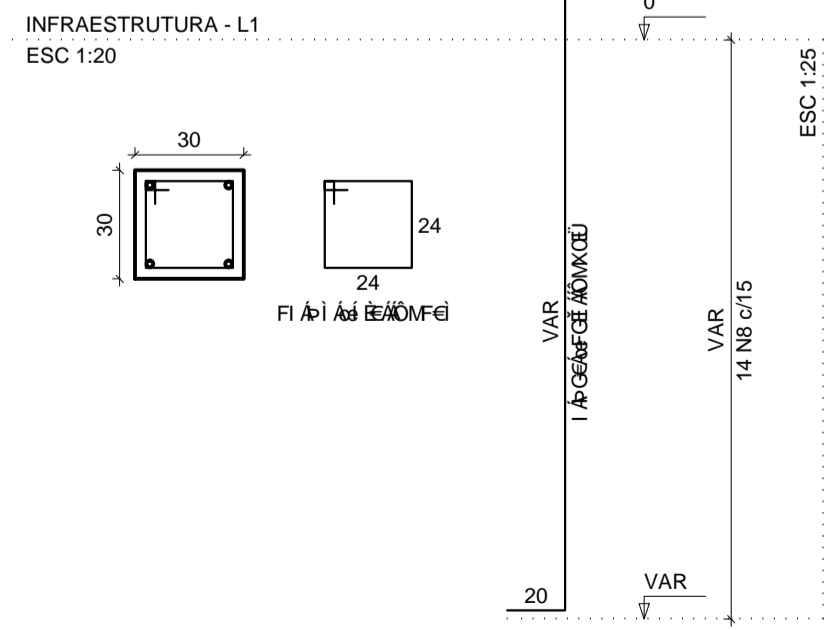

S8

PLANTA
ESC 1:25

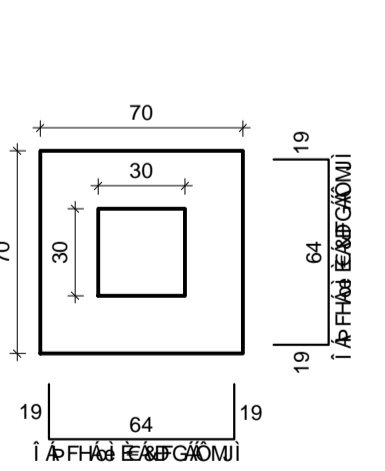

Ú (kg) / Escala / Solo compactado sobre a sapata
] (kg) / Escala / Solo compactado sobre a sapata

CORTE
ESC 1:25

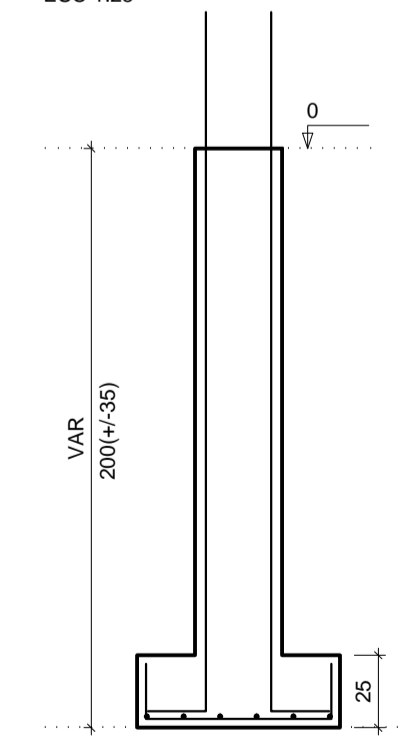

P9

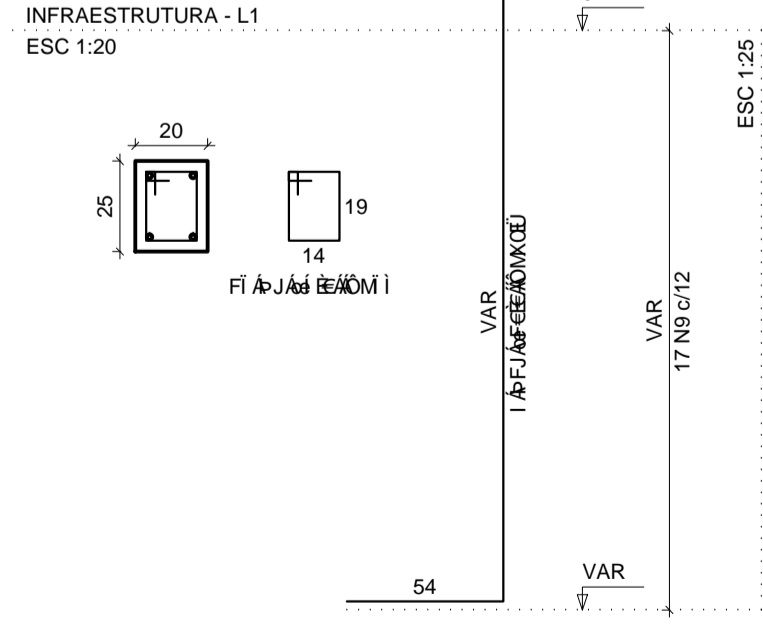

S9

PLANTA
ESC 1:25

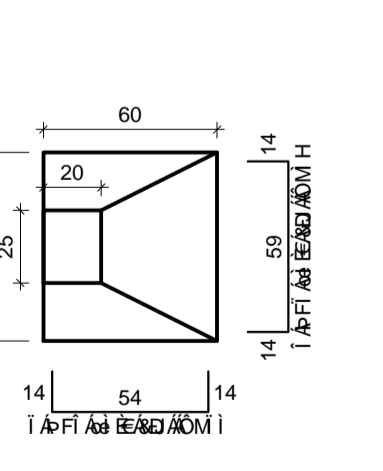

Ú (kg) / Escala / Solo compactado sobre a sapata
] (kg) / Escala / Solo compactado sobre a sapata

CORTE
ESC 1:25

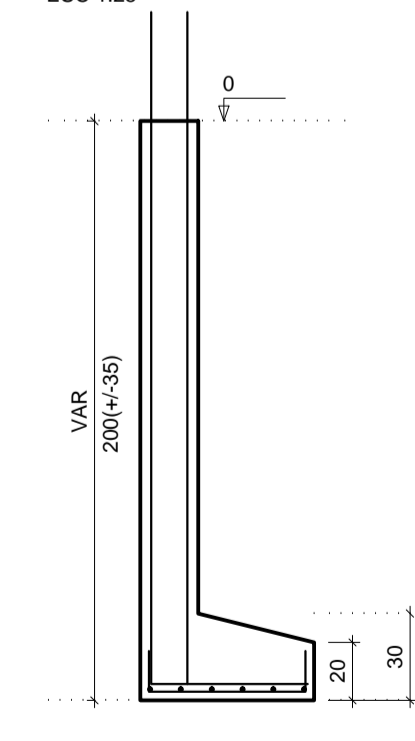

TÍTULO GALPÃO DE RECICLAGEM – BAIRRO SUMARÉ – SOBRAL/CE				
PROJETO ESTRUTURAL				
ENDEREÇO : RUA TUBIBA-BAIRRO SUMARÉ				
PROPRIETÁRIO SECOMP – SECRETARIA DE OBRAS, MOBILIDADE E SERVIÇOS PÚBLICOS PREFEITURA MUNICIPAL DE SOBRAL				
AUTOR DO PROJETO CARLOS EDUARDO BRATZ				
RESPONSÁVEL TÉCNICO CARLOS EDUARDO BRATZ				
 <p>PREFEITURA MUNICIPAL DE SOBRAL Secretaria de Obras, Mobilidade e Serviços Públicos</p>	CONTEÚDO – PLANTA SAPATAS			
	DATA	ESCALA	DESENHO	FOLHA
	06/12/2017	INDICADA	CARLOS	07/08
OBS: IMPRIMIR EM FOLHA A1				