

Uⁿ | Aⁿ | Bⁿ | Cⁿ | Dⁿ | Eⁿ | Fⁿ | Gⁿ | Hⁿ | Iⁿ | Jⁿ | Kⁿ | Lⁿ | Mⁿ | Nⁿ | Oⁿ | Pⁿ | Qⁿ | Rⁿ | Sⁿ | Tⁿ | Uⁿ | Vⁿ | Wⁿ | Xⁿ | Yⁿ | Zⁿ

Q ⁿ	U ⁿ	DIAM	Q	UN ⁿ	C.TOTAL
(cm)	(cm)	(cm)	(cm)	(cm)	(cm)
CASO	1	5,0	418	78	3304
	2	5,0	24	24	576
CASO	3	6,3	113	119	13447
	4	6,3	50	134	6700
	5	6,3	52	139	7228
	6	6,3	60	104	6240
	7	8,0	28	133	3724
	8	8,0	28	148	3268
	9	8,0	12	153	1836
	10	8,0	44	123	5412
	11	10,0	14	VAR	VAR
	12	10,0	58	VAR	VAR
	13	10,0	10	137	1370
	14	10,0	2	75	150
	15	10,0	4	VAR	VAR
	16	12,5	10	94	940
	17	15,0	4	121	484

Q ⁿ	U ⁿ	DIAM	C.TOTAL	PESO
(cm)	(cm)	(cm)	(cm)	(kg)
CASO	6,3	336,2	82,3	
	8,0	142,3	56,1	
	10,0	298,5	109,3	
	12,5	9,4	9,1	
	16,0	4,9	7,6	
CASO	8,0	331,8	51,5	
PESO TOTAL				
CASO	314,4			
CASO	51,1			

X) (Aⁿ | Bⁿ | Cⁿ | Dⁿ | Eⁿ | Fⁿ | Gⁿ | Hⁿ | Iⁿ | Jⁿ | Kⁿ | Lⁿ | Mⁿ | Nⁿ | Oⁿ | Pⁿ | Qⁿ | Rⁿ | Sⁿ | Tⁿ | Uⁿ | Vⁿ | Wⁿ | Xⁿ | Yⁿ | Zⁿ)

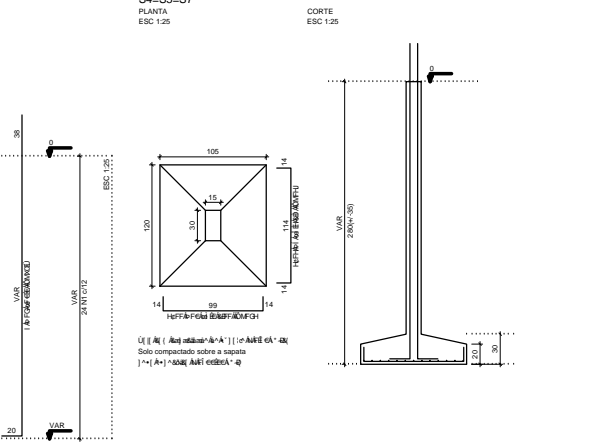
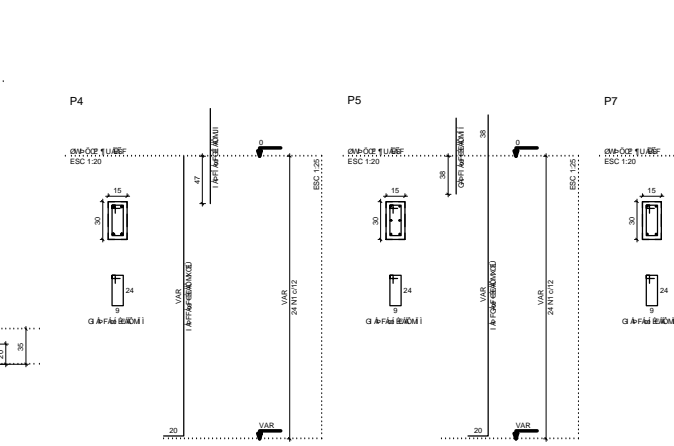
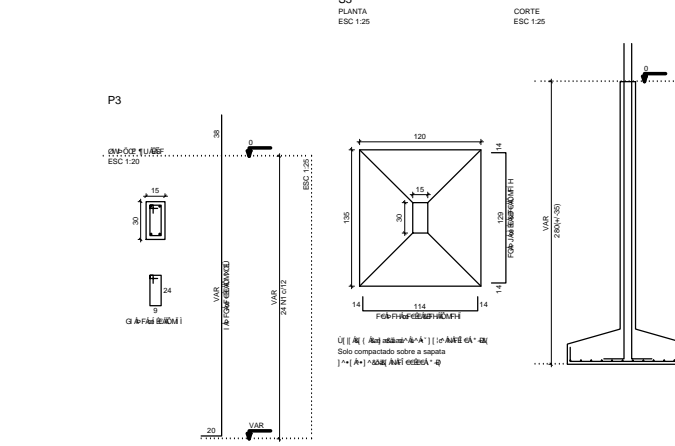

TÍTULO
CSF DE TAPERUBA, DISTRITO DO MUNICÍPIO DE SOBRAL/CE

PROJETO
ESTRUTURAL – SAPATAS

ENDEREÇO
RUA EUFRASINO BASTO, S/N, TAPERUBA – CE

PROPRIETÁRIO
PREFEITURA MUNICIPAL DE SOBRAL

AUTOR DO PROJETO
CARLOS EDUARDO BRATZ

RESPONSÁVEL TÉCNICO
CARLOS EDUARDO BRATZ

CONTEÚDO
- PLANTA DE SAPATAS

PREFEITURA MUNICIPAL DE SOBRAL
Secretaria de Obras, Meio Ambiente e Serviços Públicos

DATA 09/05/2018	ESCALA INDICADA	DESENHO CARLOS	FOLHA 01/04
---------------------------	---------------------------	--------------------------	-----------------------

OBS: IMPRIMIR EM FOLHA A1